

# IMCA Southern SportMod Dimensions For 2011

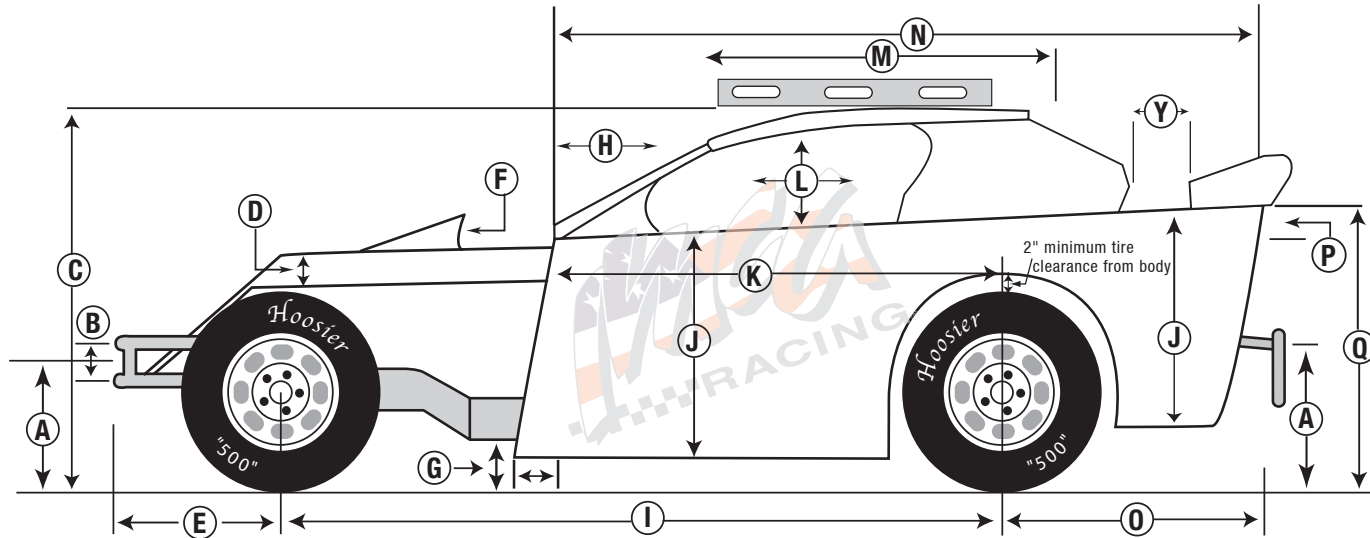

All body measurements are max. unless otherwise specified. Dimensions have zero tolerance.

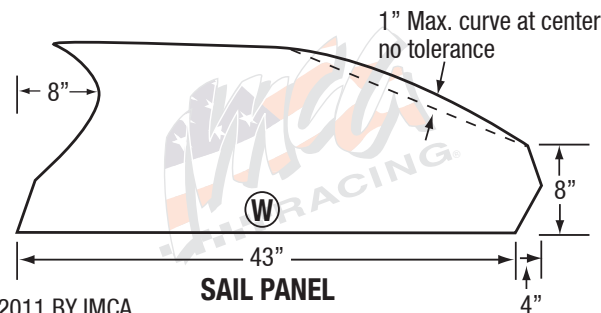
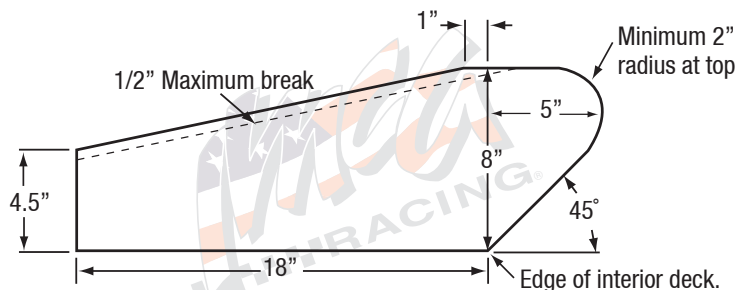
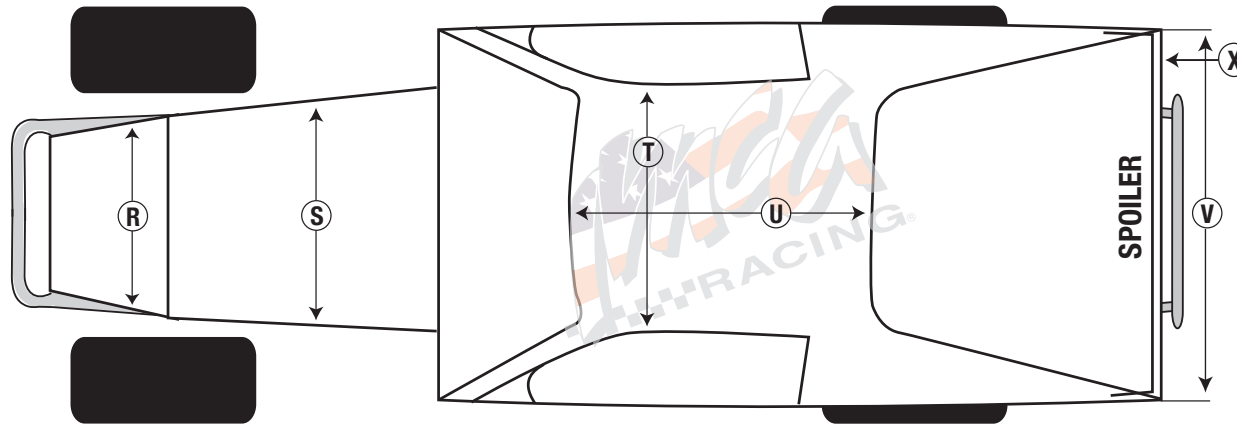

- A** 23" max. 16" min. (ground to center of bumpers, front and rear)
- B** 6.5" min. (center to center)
- C** 58" max. 42" min.
- D** Hood 5" max. drop (sides), sealed off from driver's compartment and max. 3" rake.
- E** 42" max.
- F** 6" max.
- G** 5" min. to frame rails. Door may be extended maximum 6" past block at bottom on both sides.
- H** 19" max., must be same on both sides.
- I** 109" max. 107" min.
- J** 31" max. 22" min.
- K** 67" min., or not past back of block at top.
- L** 18" max. 12" min. opening, both sides.
- M** With level, must have no more than 2" clearance at rear of roof and 5" at top front.
- N** 121" max. 98" min.
- O** 48" max. 31" min.
- P** Interior slope is 6" max. front to rear and flat across. If flat at front half of interior you have used up 50% of your 6" so from behind driver to rear you may only have 3". Top of interior must be flush with top of doors and quarters. Optional escape hatch from driver to passenger door allowed.
- Q** 41" max. 28" min.
- R** Max. no wider or lower than front frame horns, min. 24" nose must flat and flush with sides.
- S** 67" max. 24" min., must cover radiator.
- T** 53" max. 32" min.
- U** 53" max. 32" min.
- V** 67" max. 55" min., measured at top of interior deck, must be same front to back.
- W** 43" max. 24" min.
- X** IMCA decal required on car.
- Y** 3" min.

## REAR FILLER PANEL OPTIONAL

**SPOILER BRACES:** Maximum 3 total. Bottom edge of spoiler brace must be flush with rear edge of interior deck.

**SAIL PANELS:** Must be within confines of these dimensions and the same on both sides. Must mount within 2" of outside edge of interior deck.

